

**Atmospheric pressure transmitter
T2314, T2414**

with RS232 / RS485 serial output

Instruction Manual

Instruction Manual

Device type	Pressure	Output	Galvanic isolated output
T2314	✓	RS232	-
T2414	✓	RS485	✓

Device is designed for measurement of atmospheric pressure at hPa, PSI, inHg, mBar, oz/in², mmHg, inH₂O and kPa. It is possible to set pressure correction for altitude (offset). Device setting is provided by user's software, see latter. Device T2314 communicate via link RS232, device T2414 via link RS485. Supported communication protocols are Modbus RTU, protocol compatible with standard Advantech-ADAM, ARION and communication with HWg–Poseidon devices. Devices are preset from manufacturer to Modbus RTU communication protocol. If you would like to use different communication protocol then Modbus RTU, it is necessary preset them through user's software – see latter. Pressure sensor is placed inside the electronic case. Measured value is optionally shown on LCD display. Display can be switched OFF too.

Use user's software *Tsensor* for setting of all device parameters (recommended). It is free to download at www.cometsystem.cz. It supports make the adjustment of the device too. This procedure is described at file „*Calibration manual.pdf*“ which is installed commonly with the software. Change of some parameters is possible to do without user's software with Windows hyperterminal (change of communication protocol, its parameters, LCD display setting). It is described in file “*Description of communication protocols of Txxxx series*” which is free to download at the same address.

Transmitter version TxxxxL with watertight male connector instead of a cable gland (RS232) or glands (RS485) is designed for easy connection/disconnection of communication cable. Male Lumberg connector RSFM4 has protection IP67.

Models marked TxxxxZ are non-standard versions of the transmitters. Description is not included in this manual.

Please read instruction manual before the first device connection.

Device setting from the manufacturer

If special setting was not required in the order device is set from the manufacturer to the following parameters:

communication protocol:	Modbus RTU
device address:	01H
communication speed:	9600Bd, without parity, 2 stop bits
display:	switched ON
pressure unit:	hPa
correction for altitude:	0 hPa (absolute pressure)

Device installation

Device is designed for wall mounting. There are two mounting holes at the sides of the case. Don't connect device while power supply voltage is on. Interconnection terminals for T2314 and T2414 devices are accessible after unscrewing four screws and removing the lid. Lace the cable through a gland at the case wall. Connect the cable to terminals with respecting the signal polarity (see figure). Terminals are self-clamping and can be opened by a suitable screwdriver. For the opening, insert the screwdriver to smaller terminal hole and lever by him. Do not forget to tighten glands and case lid with inserted packing after cables connecting. It is necessary for warranting of protection IP54. Connect complementary female connector for T2314L and T2414L transmitters in accordance with the table in Appendix B of this manual. Working position is with communication cable entering from the top side.

Devices T2314 are supplied with connection cable equipped with connector for connection to RS232 interface. For devices with RS485 output there is recommended to use shielded twisted copper cable, maximal length 1200m. The cable must be located at indoor rooms. Nominal cable impedance should be 100 Ω , loop resistance max. 240 Ω , cable capacity max. 65 pF/m. Outside diameter of the cable for T2414 connection must be from 3 to 6.5 mm. Suitable cable is e.g. SYKFY 2x2x0.5 mm², where one wire pair serves for device powering and the other pair for communication link. For devices T2314L and T2414L use cable with respect to female connector parameters. Do NOT connect shielding at connector side.

The cable should be led in one line, i.e. NOT to „tree“ or „star“. Termination resistor should be located at the end. For short distance other topology is allowed. Terminate the network by a termination resistor. The value of the resistor is recommended about 120 Ω . For short distance termination resistor can be left out.

The cable should not be led in parallel along power cabling. Safety distance is up to 0.5 m, otherwise undesirable induction of interference signals can appear.

Electrical system (wiring) may do only worker with required qualification by rules in operation.

Info mode

If in doubt of setting of installed device, verification of its address is enabled even without using computer. Power should be connected. Devices with RS232 interface have address always set to one.

Unscrew device cover and shortly press button next to connection terminals (jumper should be opened). Actual adjusted address of the device is displayed on LCD display at decimal base, for HWg-Poseidon's communication protocol there is shown number corresponding with ASCII address code. Next press of button exits info mode and actual measured values are displayed.

Note: No measurement and communication is possible during info mode. If device stays in info mode for longer than 15 s, device automatically returns to measuring cycle.

Setting of pressure correction for altitude

If there is necessary to read value of atmospheric pressure corrected with respect to altitude, it is possible to set corresponding pressure offset for this altitude. It is possible to do it with Users software. This value is then automatically added to measured pressure value. The resultant value of pressure with added correction for altitude must be between 300 hPa and 1350 hPa (from 4.351 PSI to 19.580 PSI). Outside this range device sends value of Error 2!

Dimensions – T2314

Transmitter with RS232

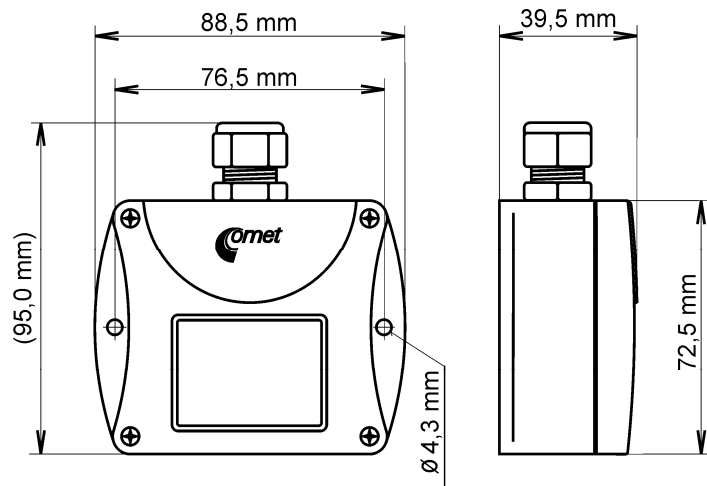

Dimensions – T2414

Transmitter with RS485

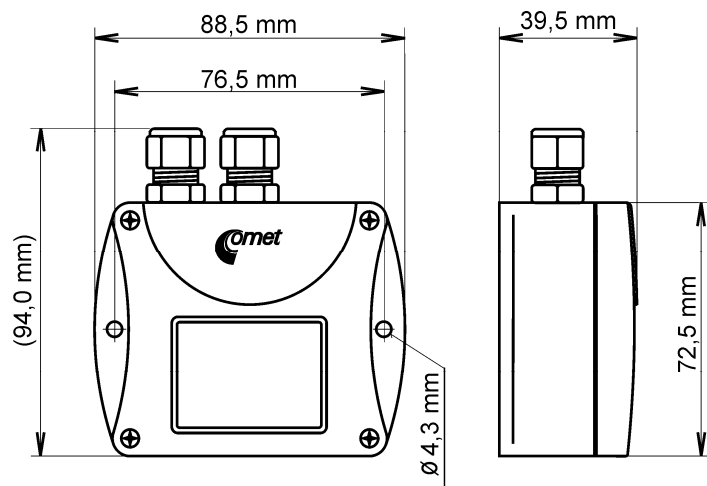

Dimensions – T2314L, T2414L

Connection: see Appendix B

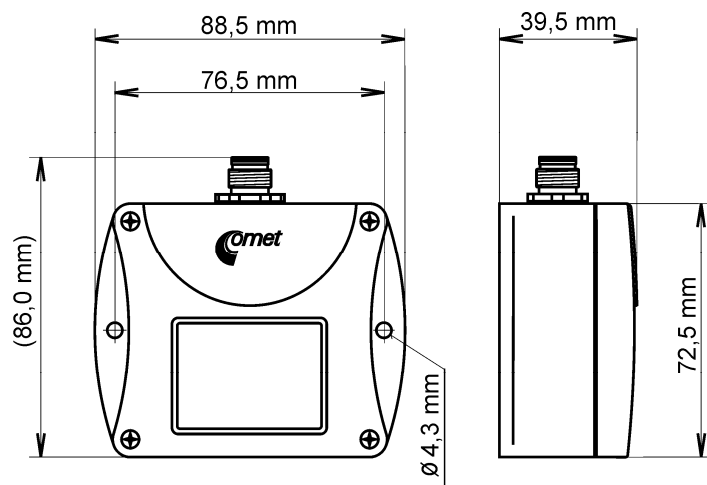

Typical application wiring, connection of terminals

T2314 - power from communication port

T2314 - power from external voltage source

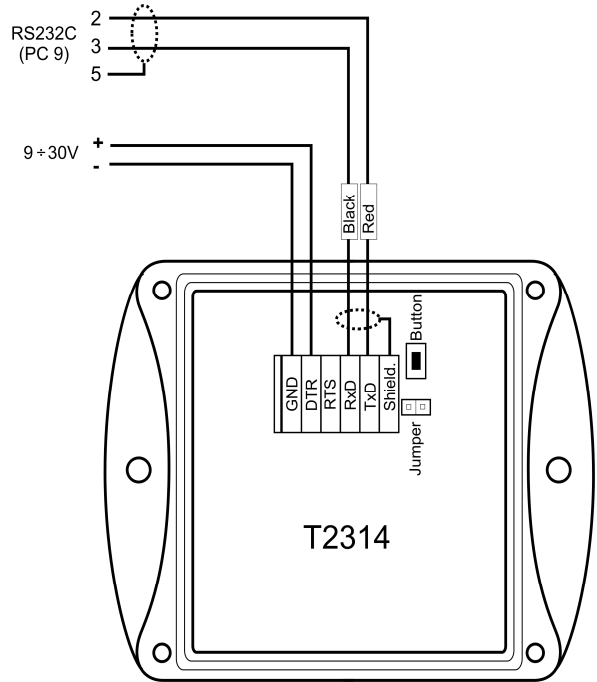
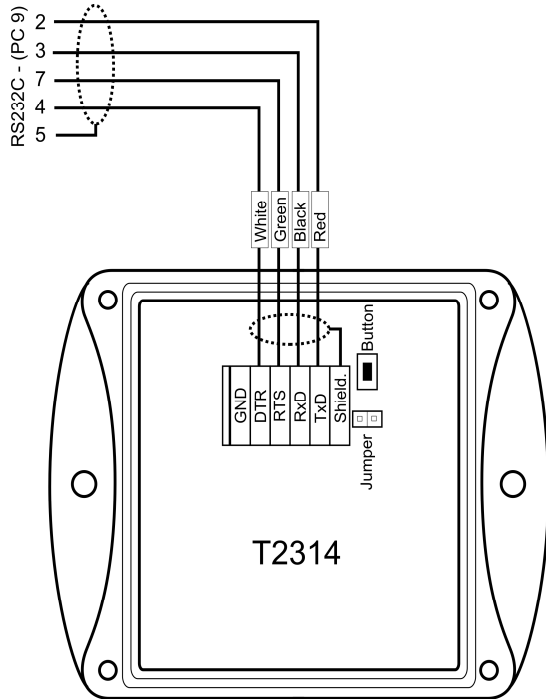

T2414 – RS485

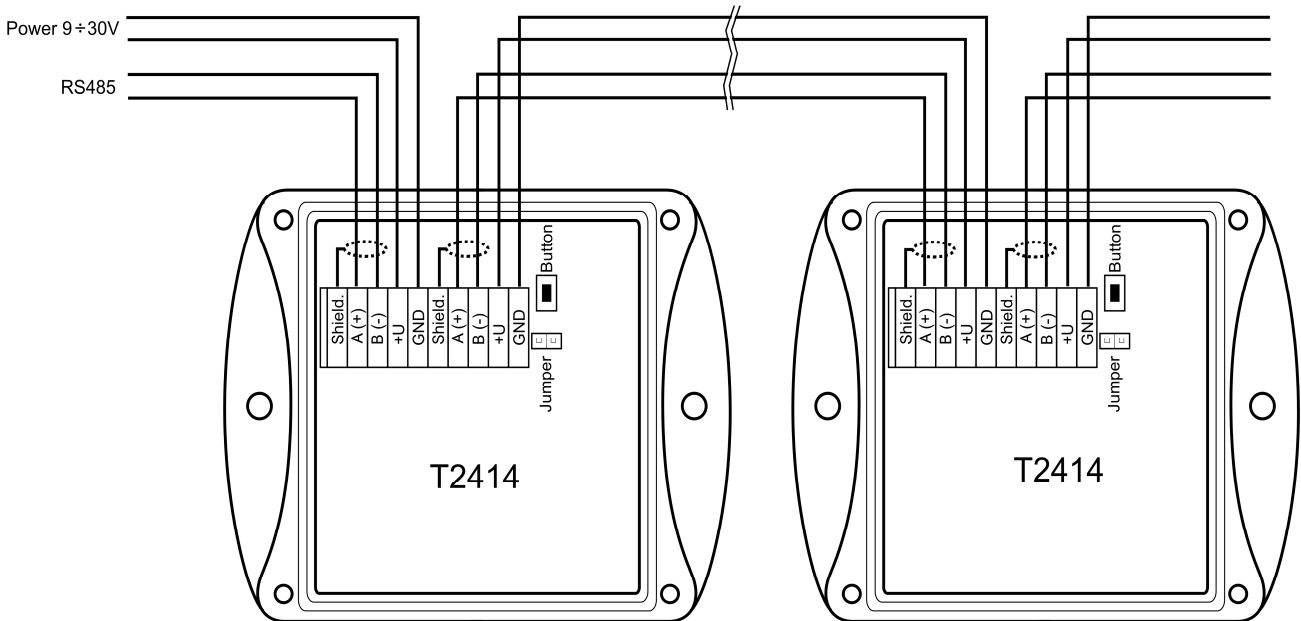

Description of communication protocols

Detailed description of each communication protocols including examples of communication is available in individual document “*Description of communication protocols of Txxxx series*” which is free to download at www.cometsystem.cz.

Note: After switching ON the power of the device it can last up to 2 s before the device starts to communicate and measure!

Modbus RTU

Control units communicate on master-slave principle in half-duplex operation. Only master can send request and only addressed device responds. During sending of request no other slave station should respond. During communication, data transfer proceeds in binary format. Each Byte is sent as eight bit data word in format: 1 start bit, data word 8 bit (LSB first), 2 stop bits¹, without parity. Device supports communication speed from 110Bd to 115200Bd.

Sent request and response have syntax: ADDRESS OF DEVICE – FUNCTION – Modbus CRC

Supported functions

03 (0x03): Reading of 16-bit registers (Read Holding Registers)

04 (0x04): Reading of 16-bit input gates (Read Input Registers)

16 (0x10): Setting of more 16-bit registers (Write Multiple Registers)

Jumper and button

Jumper and button are located next to connection terminals. If communication protocol Modbus is selected the function of jumper and button is as follows:

- Jumper opened – device memory is protected from writing, from device side it is only enabled to read measured value, writing to memory is disabled (no change of device address, communication speed and LCD setting is enabled).
- Jumper closed – writing to device memory is enabled by means of User’s software.
- Jumper opened and button shortly pressed – device goes to Info mode, see chapter „Info mode“.
- Jumper closed and button pressed for longer than six seconds – causes restoring of manufacturer setting **of communication protocol**, i.e. sets Modbus RTU communication protocol, device address sets to 01h and communication speed to 9600Bd - after button press there is “dEF” message blinking at LCD display. Six seconds later message “dEF” stays shown, it means manufacturer setting **of communication protocol** is done.

¹ Device sends two stop bits, for receive one stop bit is enough.

Modbus registers of the device

Variable	Unit	Address[hex] ^X	Address[dec] ^X	Format	Size	Status
Address of device	[-]	0x2001	8193	Int	BIN16	R/W*
Code of communication speed	[-]	0x2002	8194	Int	BIN16	R/W*
Serial number of device Hi	[-]	0x1035	4150	BCD	BIN16	R
Serial number of device Lo	[-]	0x1036	4151	BCD	BIN16	R
Version of Firmware Hi	[-]	0x3001	12289	BCD	BIN16	R
Version of Firmware Lo	[-]	0x3002	12290	BCD	BIN16	R
Atmospheric pressure	hPa	0x0034	52	Int*10	BIN16	R
	PSI			Int*1000		
	inHg			Int*100		
	mBar			Int*10		
	oz/in ²			Int*10		
	mmHg			Int*10		
	inH ₂ O			Int*10		
	kPa			Int*100		

Explanation:

- * depends on device setting (by User's software)
- Int*10 register is in format integer*10
- R register is designed only for reading
- W* register is designed for writing, for details see file "*Description of communication protocols of Txxx series*"
- ^X register addresses are indexed from zero – register 0x31 is physically sent as value 0x30, 0x32 as 0x31 (zero based addressing).

Note: In case there is a need for reading of measured values from the device with higher resolution than one decimal, measured values in device are stored also in „Float“ format, which is not directly compatible with IEEE754.

Protocol compatible with Advantech-ADAM standard

Control units communicate on master-slave principle in half-duplex operation. Only master can send requests and only addressed device responds. During sending request any of slave devices should respond. During communication data is transferred in ASCII format (in characters). Each Byte is sent as two ASCII characters. Device supports communication speed from 1200Bd to 115200Bd, parameters of communication link are 1 start bit + eight bit data word (LSB first) + 1 stop bit, without parity.

Jumper

Jumper is located next to connection terminals. If communication protocol compatible with standard Advantech-ADAM is selected, its function is the following:

- If jumper during switching ON the power is closed, device always communicates with following parameters regardless stored setting in the device:
communication speed 9600 Bd, without check sum, device address 00h

- If jumper during switching ON the power is not closed, device communicates in accordance with stored setting.
- If jumper is closed during device operation, device temporarily changes its address to 00h, it will communicate in the same communication speed as before closing jumper and will communicate without check sum. After jumper is opened setting of address and check sum is reset in accordance with values stored in the device.
- Communication speed and check sum are possible to change only if jumper is closed.
- Jumper closed and button pressed for longer than six seconds – causes restoring of manufacturer setting **of communication protocol**, i.e. sets Modbus RTU communication protocol, device address sets to 01h and communication speed to 9600Bd - after button press there is “dEF” message blinking at LCD display. Six seconds later message “dEF” stays shown, it means manufacturer setting **of communication protocol** is done.

ARION communication protocol - AMiT company

The device supports communication protocol ARiON version 1.00. For more details see file “*Description of communication protocols of Txxxx series*” or www.amit.cz.

Communication with HWg Poseidon units

Device supports communication with HWg-Poseidon units. For communication with this unit set the device with setup software TSensor to communication protocol HWg–Poseidon and set correct device address. This communication protocol supports read temperature at °C, relative humidity, one of computed value (dew point temperature or absolute humidity) and barometric pressure at kPa (depended by device type). For atmospheric pressure correction to altitude setting there is Users software Tsensor.

Jumper and button

If communication with HWg Poseidon unit is selected, the function of jumper and button is as follows:

- Jumper opened and button shortly pressed – device goes to Info mode, see chapter „Info mode“.
- Jumper closed and button pressed for longer than six seconds – causes restoring of manufacturer setting **of communication protocol**, i.e. sets Modbus RTU communication protocol, device address sets to 01h and communication speed to 9600Bd - after button press there is “dEF” message blinking at LCD display. Six seconds later message “dEF” stays shown, it means manufacturer setting **of communication protocol** is done.

Error States of the device

Device continuously checks its state during operation. In case error is found LCD displays corresponding error code:

Error 0

First line displays „Err0“.

Check sum error of stored setting inside device’s memory. This error appears if incorrect writing procedure to device’s memory occurred or if damage of calibration data appeared. At this state device does not measure and calculate values. It is a serious error, contact distributor of the device to fix.

Error 2

There is a reading „Err2“ on LCD display. Pressure measurement error occurred. Value read from the device is -999.9.

- This state occur if measured pressure value **with added correction for altitude** is outside of range from 300 hPa to 1350 hPa (from 4.351 PSI to 19.580 PSI) or the pressure sensor is damaged. Please check setting of pressure correction for altitude with User’s software.

Error 4

There is a reading „Err4“ on LCD display. It is internal device error during pressure sensor initialization. Under this condition device does NOT measure atmospheric pressure. Value read from device is -999.9. Pressure sensor is probably damaged. It is a serious error, contact distributor of the device.

Readings on LCD display

hPa, PSI, inHg,

Reading next to this symbol is measured pressure or error state of value. If selected pressure unit is **mBar** or **oz/in²** or **mmHg** or **inH₂O** or **kPa**, there is shown only value (number) without corresponding pressure unit!

symbol **3** near by left display margin
Is on if jumper is closed.

Technical parameters of the device:

RS 485 Interface:

Receiver-Input Resistance: 96 kΩ

Devices on bus: max. 256 (1/8 Unit Receiver Load)

Measuring parameters:

Atmospheric pressure (T5410 only):

Unit	hPa, mBar	PSI	mmHg	inHg	inH ₂ O	oz/in ²	kPa
Range	600	8.70	450.0	17.72	240.9	139.2	60.00
	1100	15.95	825.1	32.48	441.6	255.3	110.00
accuracy							
T=23 °C	±1.3	±0.02	±1.0	±0.04	±0.5	±0.3	±0.13
0≤T≤40°C	±1.5	±0.02	±1.1	±0.04	±0.6	±0.3	±0.15
Else	±2.0	±0.03	±1.5	±0.06	±0.8	±0.5	±0.20

Response time atmospheric pressure²: t90 <44s

Recommended calibration interval: 1 year

Measuring interval and LCD display refresh: 2 s

Power: 9 to 30 V dc

² There is possible to change response time. For more details see file “Description of calibration and adjustment procedure.pdf”, which is installed together with Users software.

Consumption: T2314 (RS232) 6 mA
T2414 (RS485) max. 0.5W

Protection: IP54

Operating conditions:

Operating temperature range: -30 to +80 °C, over +70°C switch LCD display off

Operating relative humidity range: 0 to 100 %RH

Outer influence in accordance with Czech National Standard 33-2000-3:
normal environment with those specifications: AE1, AN1, AR1, BE1

Working position: communication cable is entering from the top side

Electromagnetic compatibility: complies EN 61326-1

Not allowed manipulation

It is not allowed to operate the device under conditions other than specified in technical parameters. Devices are not designed for locations with chemically aggressive environment.

Do not use the device in an explosive environment.

Storing conditions: temperature -30 to +80 °C, humidity 0 to 100 %RH without condensation

Dimensions: see dimensional drawings

Weight: approximately T2314 cca 215 g, T2314L cca 135 g, T2414(L) cca 135 g

Material of the case: ABS

End of operation

Device itself (after its life) is necessary to liquidate ecologically!

Technical support and service

Technical support and service is provided by distributor. For contact see warranty certificate.

Appendix A

Connection of ELO E06D (RS232/RS485) and ELO 214 (USB/RS485) converters

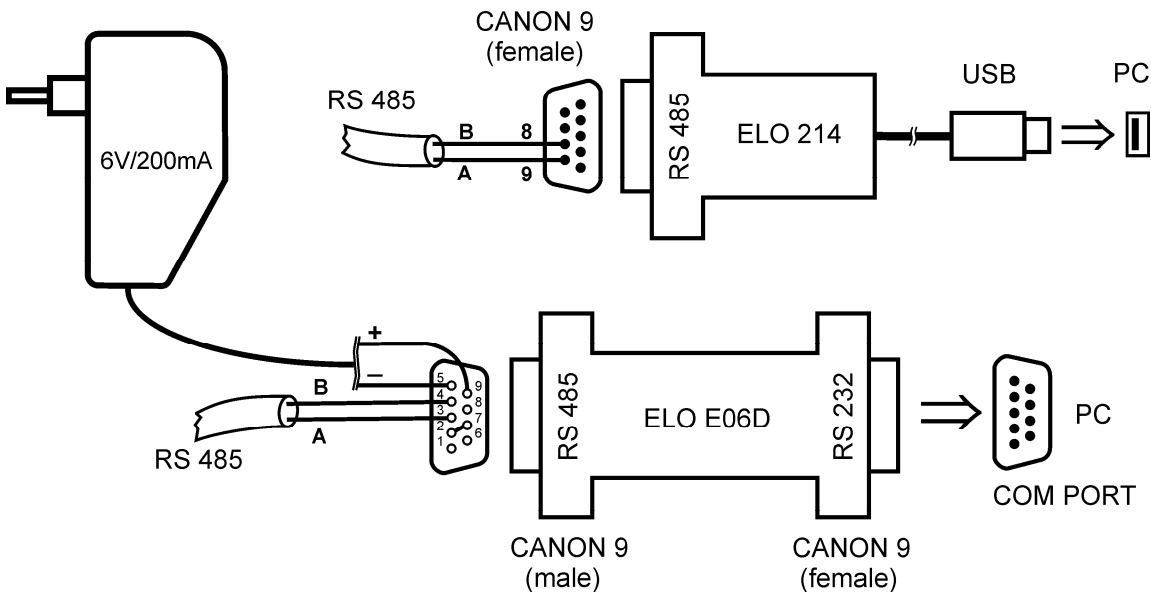

The ELO E06D converter is an optional accessory for connection of transmitter with RS485 interface to the PC via serial port RS232. Connect connector marked RS232 directly to the PC, connect power to connector marked RS485. Power voltage **+6V DC** from an external acdc adapter connect to **pin 9**, **0V** connect to **pin 5**. Also mutually connect pin 2 and pin 7. Link RS485 is connected across **pin 3 (A+)** and **pin 4 (B-)**.

The ELO 214 converter is an optional accessory for connection of transmitter with RS485 interface to the PC via USB port. Link RS485 is connected across **pin 9 (A+)** and **pin 8 (B-)**.

Appendix B

Female Lumberg connector	Transmitter Tx1xxL with 4-20mA outputs	Transmitter Tx2xxL with 0-10V outputs	Transmitter Tx3xxL with RS232 output	Transmitter Tx4xxL with RS485 output
1	+I1	Udd	RTS	+U
2	+I2	Uout1	Rx	A
3	-I2	Uout2	Tx	B
4	-I1	GND	GND	GND